

Fill in one of the fold lines with solder and bend upwards.

For normal, full width, bodies bend the outer line.

For Brake and other recessed ends, saw a slot from the outside of the etch to the inner fold line, then fold up separately

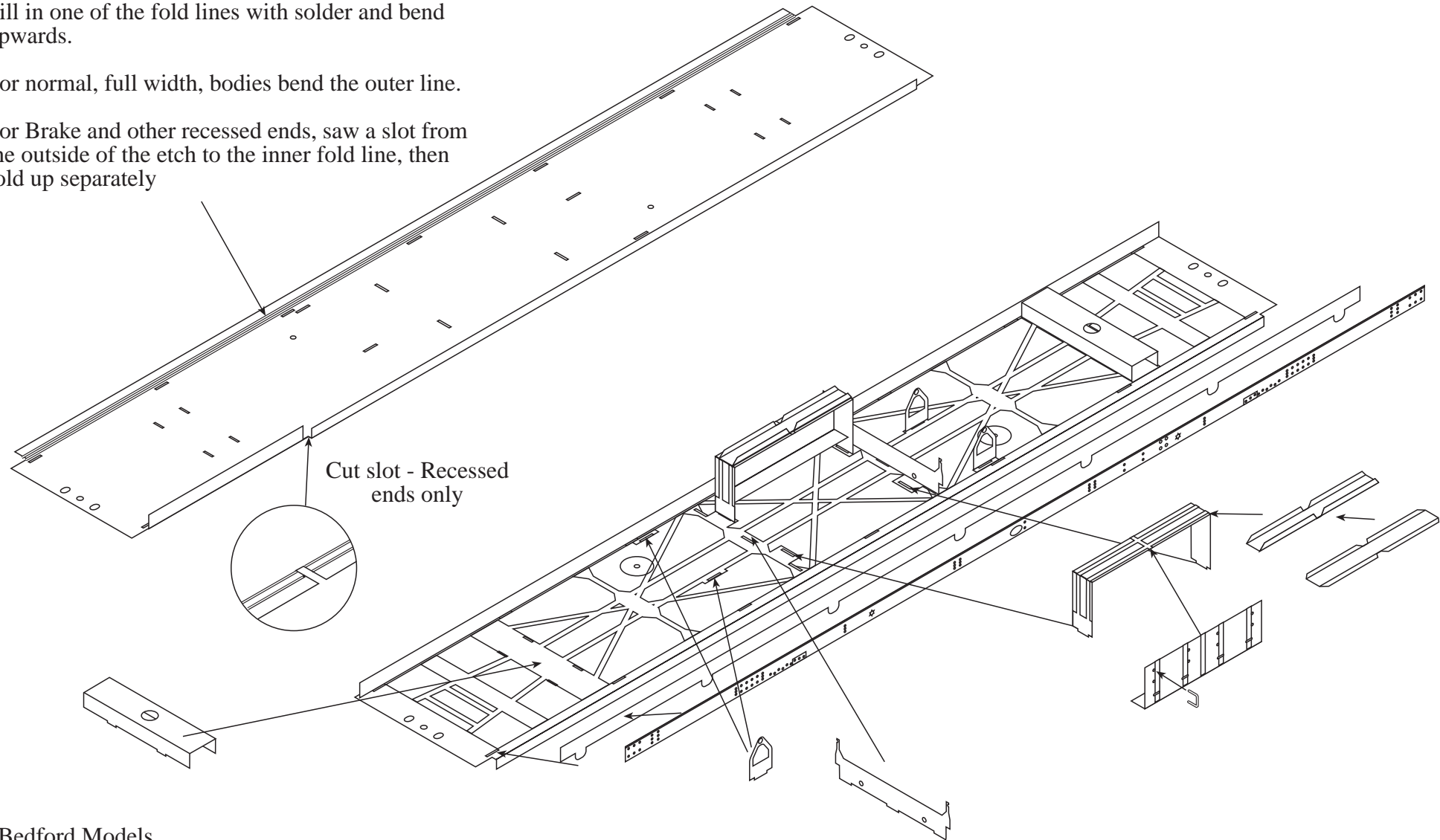

\* - Not included in kit

